



2023/2024

# Canvas

SHELVING SYSTEM

mogogo



**BASE UNIT WITH CASTERS** | HANGER BAR | ANGLED SHELF | CRATE  
BOTTLE HOLDER | SHELF | SHELF RETAINING BAR | SHELF WITH BORDER | DIVIDER

## INDEX

- 4 About Mogogo
- 8 About the Canvas Collection
- 9 Materials
- 10 How It Works
- 12 Details
- 14 Single unit - basic shelves
- 18 Single unit - mixed add-ons
- 22 Single unit - crates and more
- 28 Multi unit configurations
- 34 System breakdown
- 36 Add-ons
- 40 Express your shelf



A MODULAR F&B  
FURNITURE BRAND

# BORN FROM A PASSION FOR **STYLE & GASTRONOMY**



Mogogo is led by designers and chefs that are aiming to introduce innovative, luxurious, and highly functional equipment to foodservice professionals.



LINENLESS



MODULAR



MOBILE



SUSTAINABLE



ADD ONS



\*BACK BAR UNIT SEE PAGE 30

MIXOLOGY SERVICE CART C-RNX-03-BSXX

ROUND POLO DISPLAY TABLE C-PPR-01-MBXX

PRO BAR STATION C-MLC-05-GSXW

\*ALL PICTURES SHOWN ARE FOR ILLUSTRATION PURPOSES ONLY. ACTUAL PRODUCTS MAY VARY.



## ABOUT THE CANVAS COLLECTION

The Canvas Collection is an innovative shelving system for the hospitality sector, acting as a blank page allowing professionals to accomplish their creative vision. The collection is ideal as a back bar or for showcasing food and beverages and related products.

It combines function with uncluttered aesthetics to create this versatile range of shelving, taking into consideration the unique and challenging requirements of foodservice.



## MATERIALS

The usage of ecological materials is part of a global movement that aims to convey the message that luxury and sustainability go together. The bamboo frame is lightweight and highly structural, joined by decorative metal features to create a fine balance between traditional woodcraft and modern design.

Natural horizontal bamboo | Sandblasted Stainless Steel. NATURAL

Dark brown stained bamboo | Sandblasted Copper-plated Stainless Steel. DARK LUX



Watch our video to learn more about  
the Canvas collection

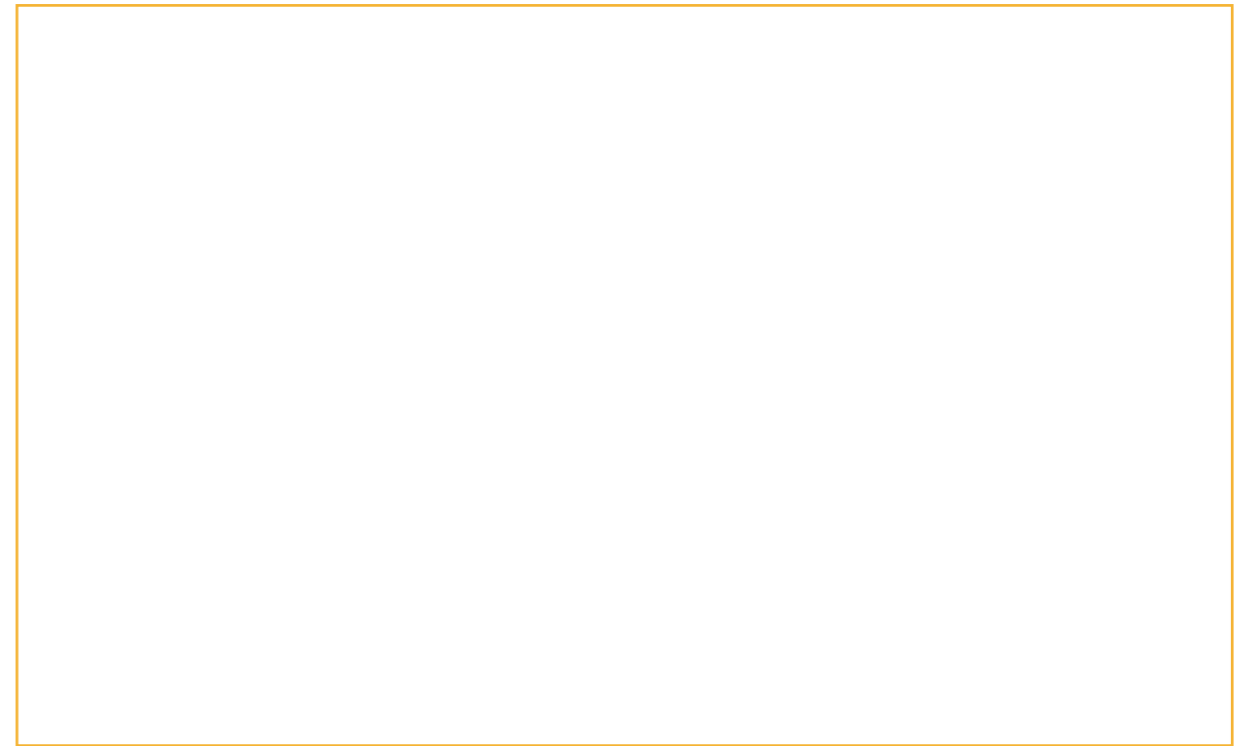

See more videos by Mogogo here

## HOW IT WORKS

Starting with an unfilled Canvas structure then adding selected fixtures, allows creating stations with specific needs, and the ability to seamlessly connect several units offers the flexibility to construct configurations fitting any size or shape of space.

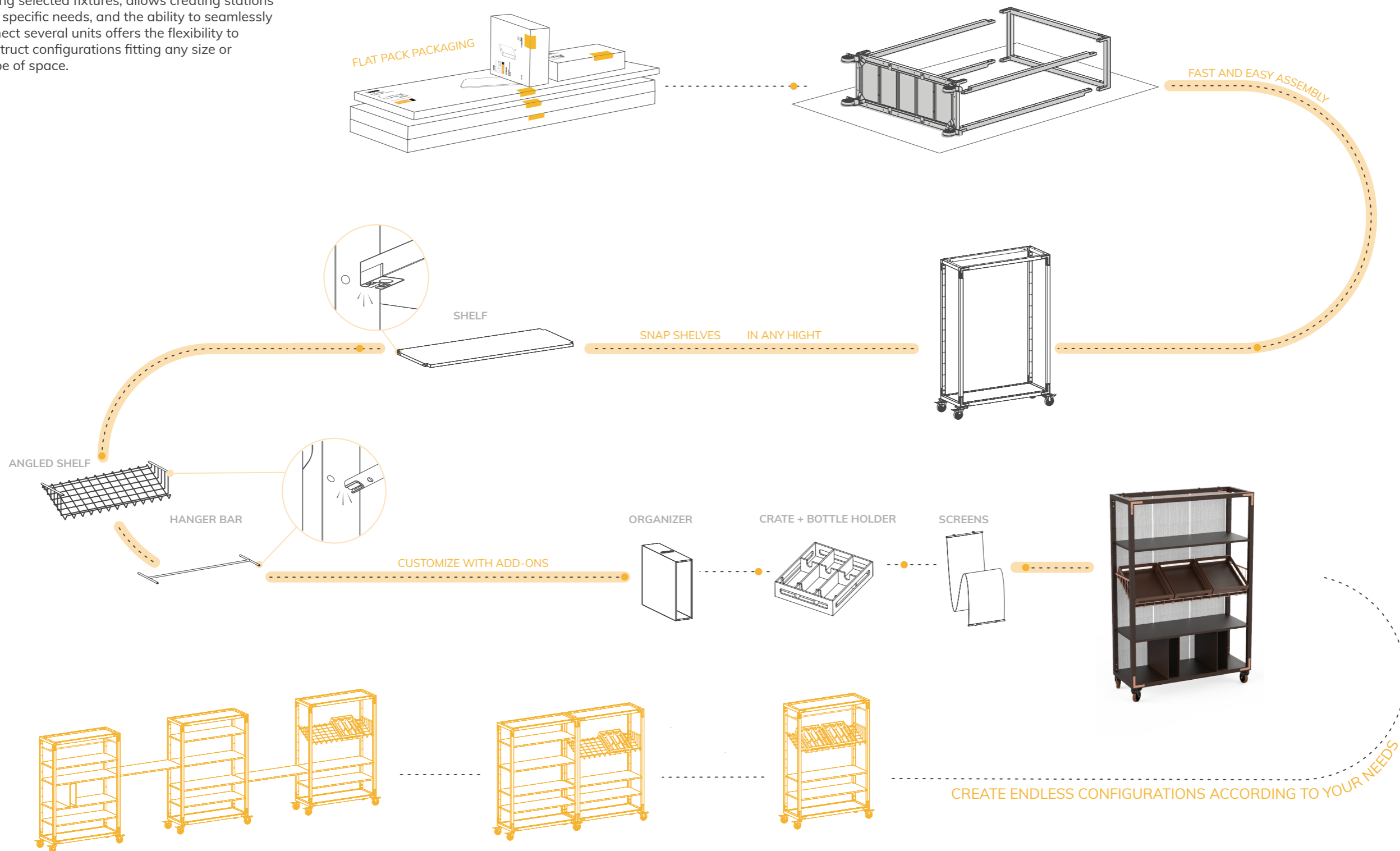

**DETAILS**

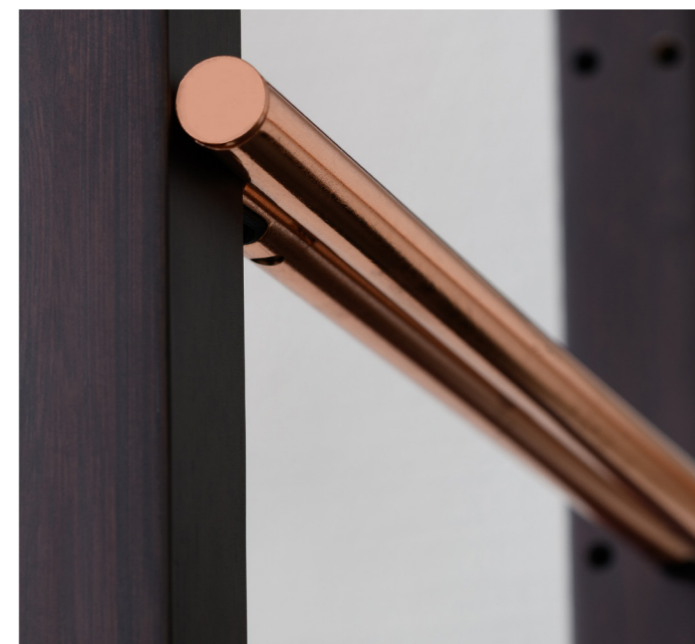
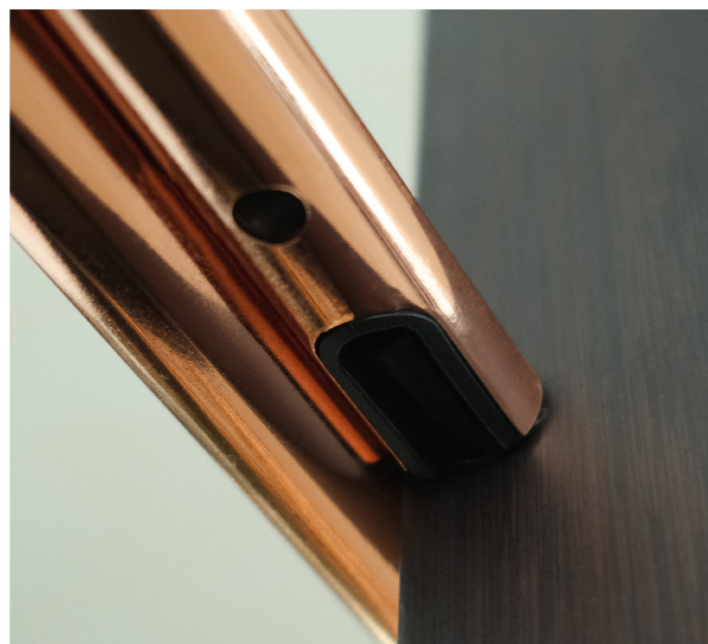

**EXPRESS  
YOUR  
SHELF**





BUSSING STATION C-CAN-14-NSXW



### SINGLE UNIT - BASIC SHELVES

Organization and accessibility are foundation stones for a functional station. Whether it is used front of house or behind the scenes, several shelves can be set at different heights in a matter of seconds creating a practical and stylish tool.

The unit can be covered partially or completely with the use of easy to install screens.

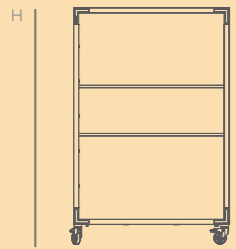
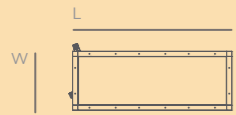

L48½" W18" H73½"  
L122.5cm W46cm H186cm



**TWO SHELF UNIT**

- NATURAL | CASTERS ..... C-CAN-17-NSXW
- NATURAL | LEGS ..... C-CAN-17-NSXF
- DARK-LUX | CASTERS ..... C-CAN-17-DCXW
- DARK-LUX | LEGS ..... C-CAN-17-DCXF

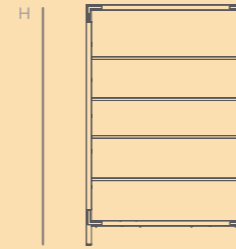
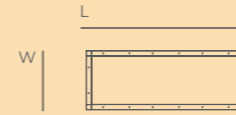

L48½" W18" H73½"  
L122.5cm W46cm H186cm



**FOUR SHELF UNIT**

- NATURAL | CASTERS ..... C-CAN-18-NSXW
- NATURAL | LEGS ..... C-CAN-18-NSXF
- DARK-LUX | CASTERS ..... C-CAN-18-DCXW
- DARK-LUX | LEGS ..... C-CAN-18-DCXF

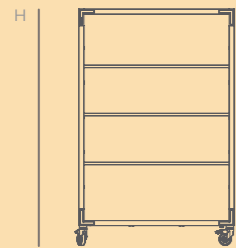
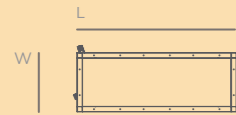

L48½" W18" H73½"  
L122.5cm W46cm H186cm



**THREE SHELF UNIT**

- NATURAL | CASTERS ..... C-CAN-14-NSXW
- NATURAL | LEGS ..... C-CAN-14-NSXF
- DARK-LUX | CASTERS ..... C-CAN-14-DCXW
- DARK-LUX | LEGS ..... C-CAN-14-DCXF

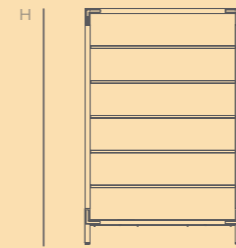
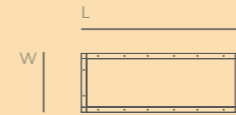

L48½" W18" H73½"  
L122.5cm W46cm H186cm



**FIVE SHELF UNIT**

- NATURAL | CASTERS ..... C-CAN-09-NSXW
- NATURAL | LEGS ..... C-CAN-09-NSXF
- DARK-LUX | CASTERS ..... C-CAN-09-DCXW
- DARK-LUX | LEGS ..... C-CAN-09-DCXF

## SINGLE UNIT - MIXED ADD-ONS

Mixing and matching is as simple as ever, and while installing the add-ons is user-friendly, the outcome is sophisticated and versatile. The shelf selection and designated add-ons are intended to offer you the freedom of expression when presenting food and beverage or your decoration of choice.



ROOM DIVIDER C-CAN-08-DCXW

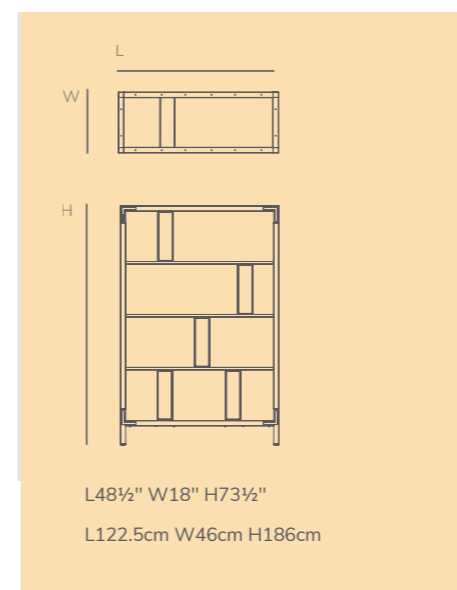
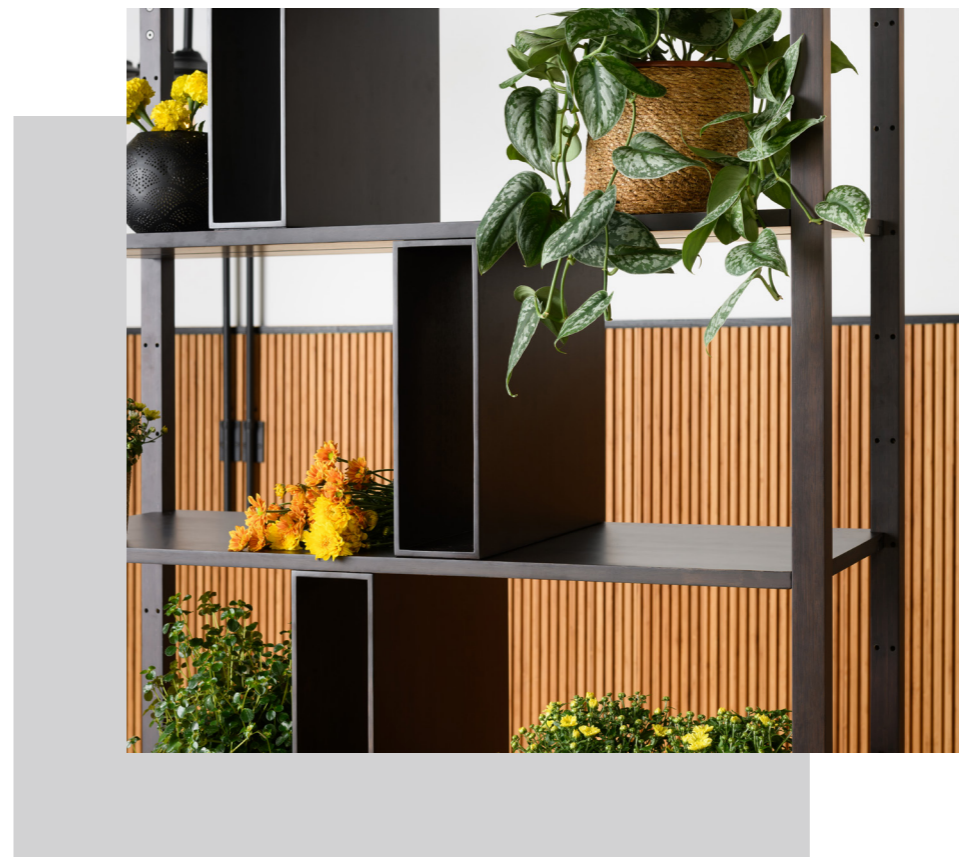

### ROOM DIVIDER

This Room Divider creates a sophisticated atmosphere and lining up multiple units can create division and a seamless appearance to any space. The shelf rail allows the dividers to be moved easily while in place to achieve a customized solution for your specific needs.



- NATURAL | CASTERS.....C-CAN-08-NSXW
- NATURAL | LEGS.....C-CAN-08-NSXF
- DARK-LUX | CASTERS.....C-CAN-08-DCXW
- DARK-LUX | LEGS.....C-CAN-08-DCXF



**DESSERT STATION**

This unit aims to focus attention on selected food items, such as exquisite "petit fours" or other food creations you wish to treat and showcase as jewels. It comes with two shelves and a slick sign to let your guests know what all the fuss is about.

- **NATURAL | CASTERS**.....C-CAN-15-NSXW
- NATURAL | LEGS.....C-CAN-15-NSXF
- DARK-LUX | CASTERS.....C-CAN-15-DCXW
- DARK-LUX | LEGS.....C-CAN-15-DCXF

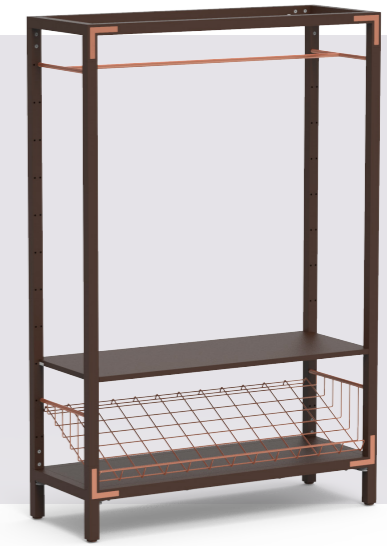
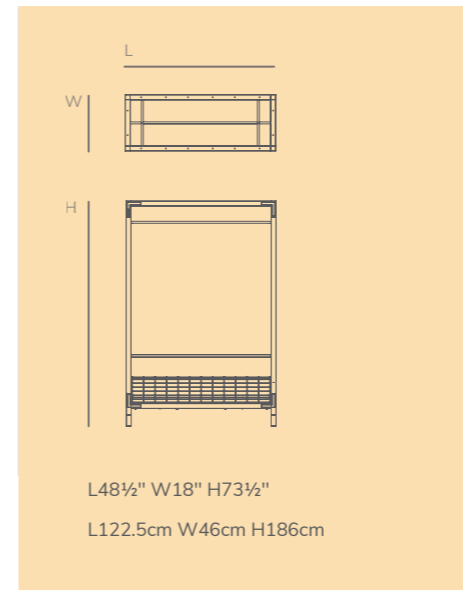

**COAT RACK**

The Canvas system function can be stretched beyond the common usage to other hospitality areas, such as this portable coat rack station and many others, helping to overcome your daily challenges.

- NATURAL | CASTERS.....C-CAN-11-NSXW
- NATURAL | LEGS.....C-CAN-11-NSXF
- DARK-LUX | CASTERS.....C-CAN-11-DCXW
- **DARK-LUX | LEGS**.....C-CAN-11-DCXF

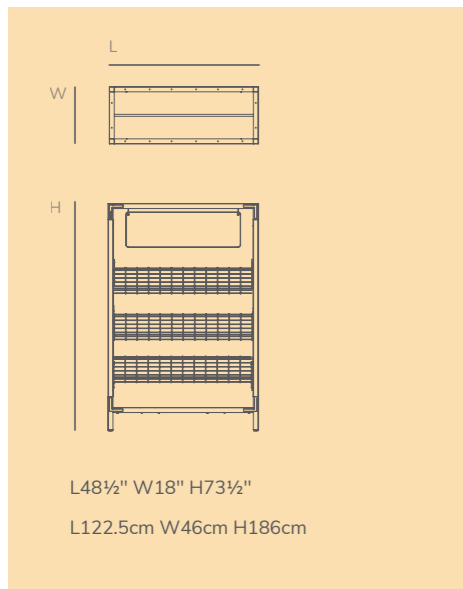

**ANGLED SHELF SIGNAGE UNIT**

This unit takes food presentation seriously! The angled stainless steel wire shelf offers food and related ingredients to be presented in an optimal style, and the hanging blackboard sign allows you to compose a unique story time after time.

- NATURAL | CASTERS.....C-CAN-16-NSXW
- **NATURAL | LEGS**.....C-CAN-16-NSXF
- DARK-LUX | CASTERS.....C-CAN-16-DCXW
- DARK-LUX | LEGS.....C-CAN-16-DCXF



**HANGING UNIT**

A clean and mentalistic hanging station offers to use the Canvas in exacting ways and discover new ideas to wow your guests, such as an indoor vertical herb garden or other ideas that you will come up with.

- NATURAL | CASTERS.....C-CAN-10-NSXW
- NATURAL | LEGS.....C-CAN-10-NSXF
- **DARK-LUX | CASTERS**.....C-CAN-10-DCXW
- DARK-LUX | LEGS.....C-CAN-10-DCXF



GRAB AND GO SIGNAGE UNIT C-CAN-03-NSXW



### SINGLE UNIT - CRATES AND MORE

This group of configurations is defined by the crates they hold, allowing the operator to store and display most anything they wish. Combined with shelving and signage, they can perform many functions in a variety of locations while offering versatility and beauty.

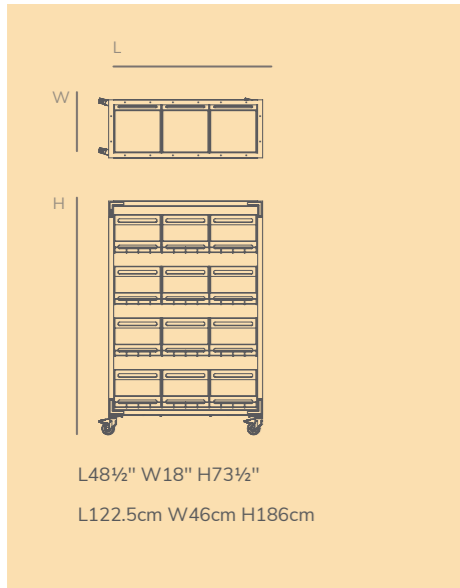

**ANGLED SHELF UNIT**

The wooden display crates with fresh vegetables, breads, combined with the olive oil bottles, bags of flour and other quality ingredients, are sure to tell your guest that a wonderful dish is on the way. Ultimately, completing the sensory experience that is so essential in hospitality!

- **NATURAL | CASTERS**..... C-CAN-12-NSXW
- NATURAL | LEGS..... C-CAN-12-NSXF
- DARK-LUX | CASTERS..... C-CAN-12-DCXW
- DARK-LUX | LEGS..... C-CAN-12-DCXF

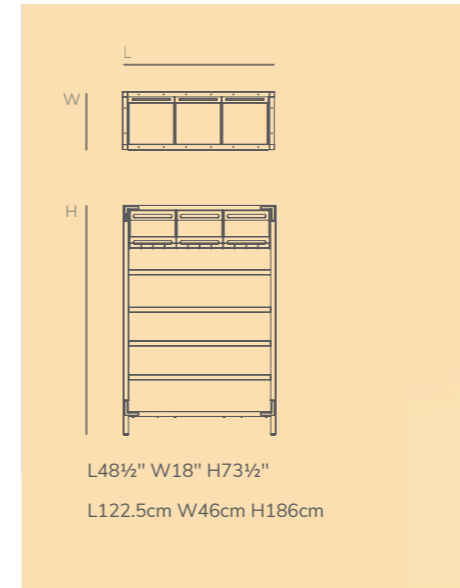

**GRAB AND GO UNIT**

Snacks, fruit and a variety of goods your guests desire to Grab and Go, will be displayed perfectly on this Canvas configuration. The angled shelf will improve visibility and create a complete experience.

- NATURAL | CASTERS..... C-CAN-02-NSXW
- NATURAL | LEGS..... C-CAN-02-NSXF
- DARK-LUX | CASTERS..... C-CAN-02-DCXW
- **DARK-LUX | LEGS**..... C-CAN-02-DCXF

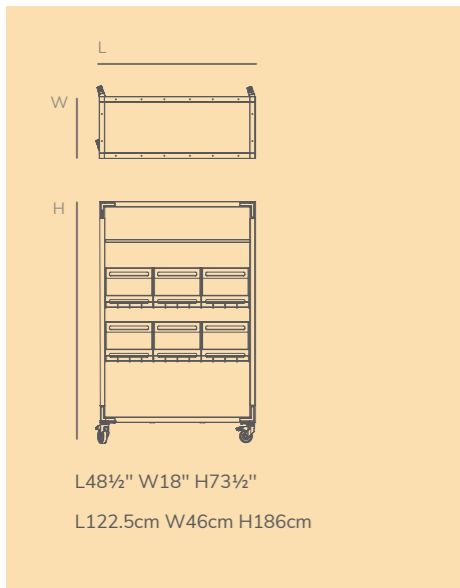

**FARM TO TABLE**

What is more appetizing than knowing that what you are about to eat is made from farm fresh ingredients. This Farm to Table Station was developed with this in mind and provides you a variety of display solutions that can effortlessly be customized according to the menu.

- NATURAL | CASTERS..... C-CAN-04-NSXW
- NATURAL | LEGS..... C-CAN-04-NSXF
- **DARK-LUX | CASTERS**..... C-CAN-04-DCXW
- DARK-LUX | LEGS..... C-CAN-04-DCXF

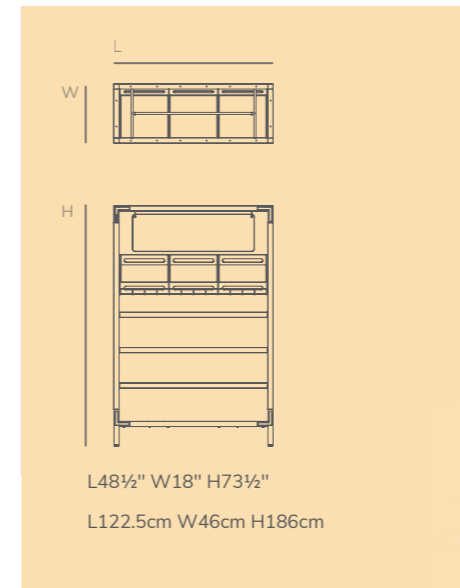

**GRAB AND GO SIGNAGE UNIT**

Like the Grab and Go unit above, it has the angled shelf, but also includes a chalkboard to make it very clear to your guests that tasty treats are available.

- NATURAL | CASTERS..... C-CAN-03-NSXW
- **NATURAL | LEGS**..... C-CAN-03-NSXF
- DARK-LUX | CASTERS..... C-CAN-03-DCXW
- DARK-LUX | LEGS..... C-CAN-03-DCXF



**FARM TO TABLE** C-CAN-04-DCXW  
**THREE SHELF UNIT** C-CAN-14-NSXW  
**GRAB AND GO SIGNAGE UNIT** C-CAN-03-NSXW



**CENTER STAGE DISPLAY C-CAN-19-NSXW**  
 (Shown with optional Golden-Brown screens)

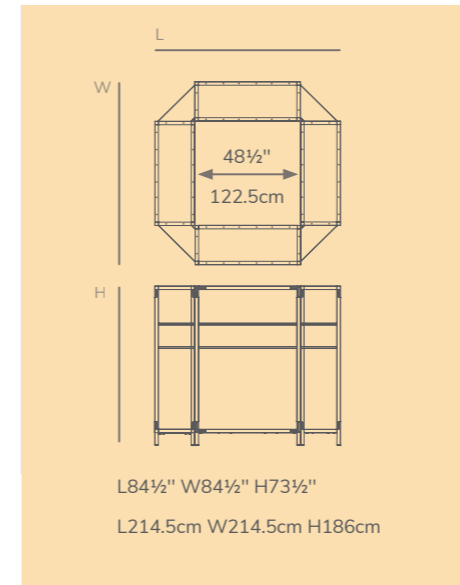

**CENTER STAGE DISPLAY**

Whether you're trying to make a statement in the middle of your room or wanting to utilize the space around that awkward pillar, this station will do both. The ability to connect the Canvas shelving units with the corner shelf connectors adds a dimension the traditional buffet furniture lacks and the results can be functional and stunning.

- NATURAL | CASTERS.....C-CAN-19-NSXW
- NATURAL | LEGS.....C-CAN-19-NSXF
- DARK-LUX | CASTERS.....C-CAN-19-DCXW
- DARK-LUX | LEGS.....C-CAN-19-DCXF

**MULTI UNIT CONFIGURATIONS**

If your space allows the use of several units, the addition of the unit connectors, straight shelves and corner shelves, is a cost effective way to add additional display space. In addition, it creates straight or angled structures that act as living walls, allowing you to express your artistic talents.







**BACK BAR UNIT**

A luxurious back bar tells a story and lets your guest know that they have arrived at their destination and will be treated accordingly. Whether they seek a revitalizing cocktail or a glass of wine, the look and feel you create will set the tone.

- **NATURAL | CASTERS** ..... C-CAN-05-NSXW
- NATURAL | LEGS ..... C-CAN-05-NSXF
- DARK-LUX | CASTERS** ..... C-CAN-05-DCXW
- DARK-LUX | LEGS ..... C-CAN-05-DCXF



**COFFEE LOUNGE**

Double espresso, butter Croissant, and the newspaper of the day! No matter where you wake up, it's a great way to start another busy day. The flexibility of the Canvas Collection can turn your pleasant but hard to utilize space into an attractive area that gives a look and feel of a neighborhood café.

- NATURAL | CASTERS ..... C-CAN-07-NSXW
- NATURAL | LEGS ..... C-CAN-07-NSXF
- DARK-LUX | CASTERS ..... C-CAN-07-DCXW
- **DARK-LUX | LEGS** ..... C-CAN-07-DCXF



**WINE DISPLAY**

At the end of the day, a glass of red wine, cheese, and snacks can turn into a worthy memory. This elegant configuration allows for the serving of wine and related foods in a way that is sure to impress. Each unit comes with casters allowing for easy mobility when moving from one event to another.

- NATURAL | CASTERS ..... C-CAN-06-NSXW
- NATURAL | LEGS ..... C-CAN-06-NSXF
- **DARK-LUX | CASTERS** ..... C-CAN-06-DCXW
- DARK-LUX | LEGS ..... C-CAN-06-DCXF



**SELF SERVICE**

Juice boxes or sweets? What decorations will enhance the experience to create something modern and minimalist, or a warmer and more country style. The self service configuration gives you the tools to express your desired concept no matter what the occasion is.

- **NATURAL | CASTERS** ..... C-CAN-01-NSXW
- NATURAL | LEGS ..... C-CAN-01-NSXF
- DARK-LUX | CASTERS ..... C-CAN-01-DCXW
- DARK-LUX | LEGS ..... C-CAN-01-DCXF

CDG	ULC	8655	2	161 - 164	CHECK-IN
NHAGEN	OS	0708	2	245 - 247	CHECK-IN
IN	CZ	7122	2	204 - 205	CHECK-IN
I	DY	3581	2	KIOSK	
	EI	0645	1	KIOSK	
	EK	0140	1	171 - 178	CHECK-IN



**COFFEE LOUNGE C-CAN-07-DCXW**  
(shown with optional Charcoal-Black Screens)



C-CAN-04-DCXW

## SYSTEM BREAKDOWN

Starting with a blank rectangular structure (on casters or legs) acting as an empty page that awaits your ideas and needs to be explored. Our Canvas Shelving System was born from the basic idea that your F&B Furniture should adapt to your ever-varying needs during different functions. It allows you to pick and choose basic elements such as shelves with or without borders, hanging bars, signs, organizers, and more.

## BUILD YOUR OWN UNITS

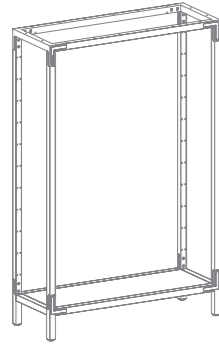

**EMPTY UNIT WITH LEGS**  
L48½" W18" H73½"  
L122.5cm W46cm H186cm



Natural horizontal bamboo sandblasted stainless steel

C-CAN-13-NSXF



Dark brown stained bamboo Sandblasted Copper plating

C-CAN-13-DCXF

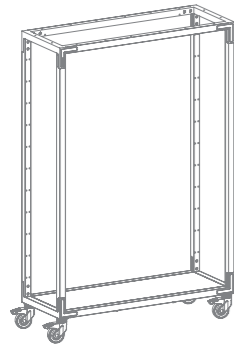

**EMPTY UNIT WITH CASTERS**  
L48½" W18" H73½"  
L122.5cm W46cm H186cm

C-CAN-13-NSXW

C-CAN-13-DCXW

## ADD-ONS SHELVES

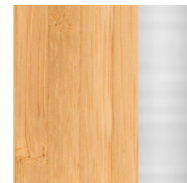

Natural horizontal bamboo sandblasted stainless steel

S-CAN-BM-02

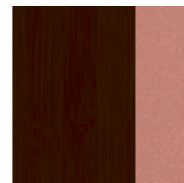

Dark brown stained bamboo Sandblasted Copper plating

S-CAN-DB-02



**SHELF**  
L46½" W18" H0.8"  
L118.5cm W46cm H2cm



**SHELF WITH BORDER**  
L46½" W18" H1½"  
L118.5cm W46cm H4cm

S-CAN-BM-07

S-CAN-DB-07



**TOP FRAME SHELF**  
L45" W15" H0.8"  
L114.5cm W38cm H2cm

S-CAN-BM-06

S-CAN-DB-06

## ADD-ONS



Natural horizontal bamboo sandblasted stainless steel

S-CAN-SS-01

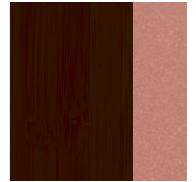

Dark brown stained bamboo Sandblasted Copper plating

S-CAN-SC-01



**HANGER BAR**  
Comes with 5 Hooks  
L46½" W15" H½"  
L118cm W38cm H1.6cm



**TOP FRAME HANGER BAR**  
Comes with 5 Hooks  
L38" W16½" H½"  
L96cm W41.5cm H1.5cm

S-CAN-SS-02

S-CAN-SC-02

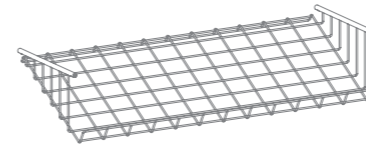

**ANGLED SHELF**  
Can fit up to 3 crates  
L46½" W18" H9½"  
L118cm W46cm H24cm

S-CAN-SS-03

S-CAN-SC-03



**SHELF RETAINING BAR**  
L46½" W18" H0.6"  
L118cm W46cm H1.6cm

S-CAN-SS-04

S-CAN-SC-04

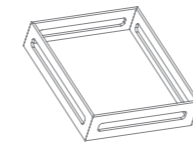

**CRATE**  
L17½" W14.½" H4"  
L44cm W37.5cm H10cm

S-CAN-BM-03

S-CAN-DB-03

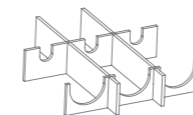

**BOTTLE HOLDER**  
fits Crate  
L16½" W14" H3½"  
L42.5cm W36cm H8.5cm

S-CAN-BM-04

S-CAN-DB-04

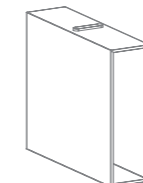

**ORGANIZER**  
L18" W4½" H15½"  
L46cm W12cm H39cm

S-CAN-BM-05

S-CAN-DB-05

## ADD-ONS

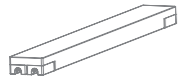

**UNIT CONNECTORS**  
To connect two units | Set of 2  
L15" W1.5" H0.8"  
L38cm W4cm H2cm



Natural horizontal  
bamboo sandblasted  
stainless steel

S-CAN-BM-09



Dark brown stained  
bamboo Sandblasted  
Copper plating

S-CAN-DB-09



**CORNER SHELF CONNECTOR**  
To connect two units in 90° | Set of 2  
L18" W18" H0.8"  
L46cm W46cm H2cm

S-CAN-BM-11

S-CAN-DB-11

## MISCELLANEOUS ADD-ONS

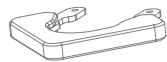

**BUMPERS**  
set of 4  
L5" W5" H0.6"  
L12cm W12cm H1.6cm

S-CAN-SM-08

S-CAN-SM-08

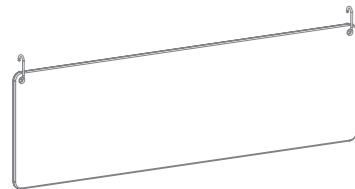

**SIGN**  
Comes with 2 Hooks  
L37" W11½" H½"  
L94cm W29cm H1cm

S-CAN-SM-09

S-CAN-SM-09

## SCREENS

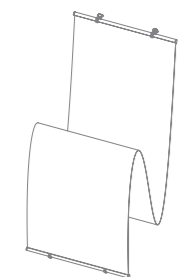

**EASY TO INSTALL SCREENS**  
Set of 5- Available in various colors  
L67" W15"  
L170cm W38cm

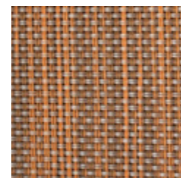

Golden-Brown

S-CAN-PV-02

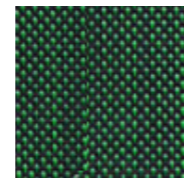

Jungle-Green

S-CAN-GP-01

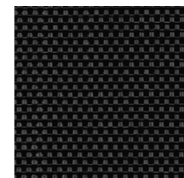

Charcoal-Black

S-CAN-PV-01



COAT RACK C-CAN-11-NSXW

Sketch your own Canvas configuration by choosing from a variety of shelves and add-ons using the 2D drawing to explore options.

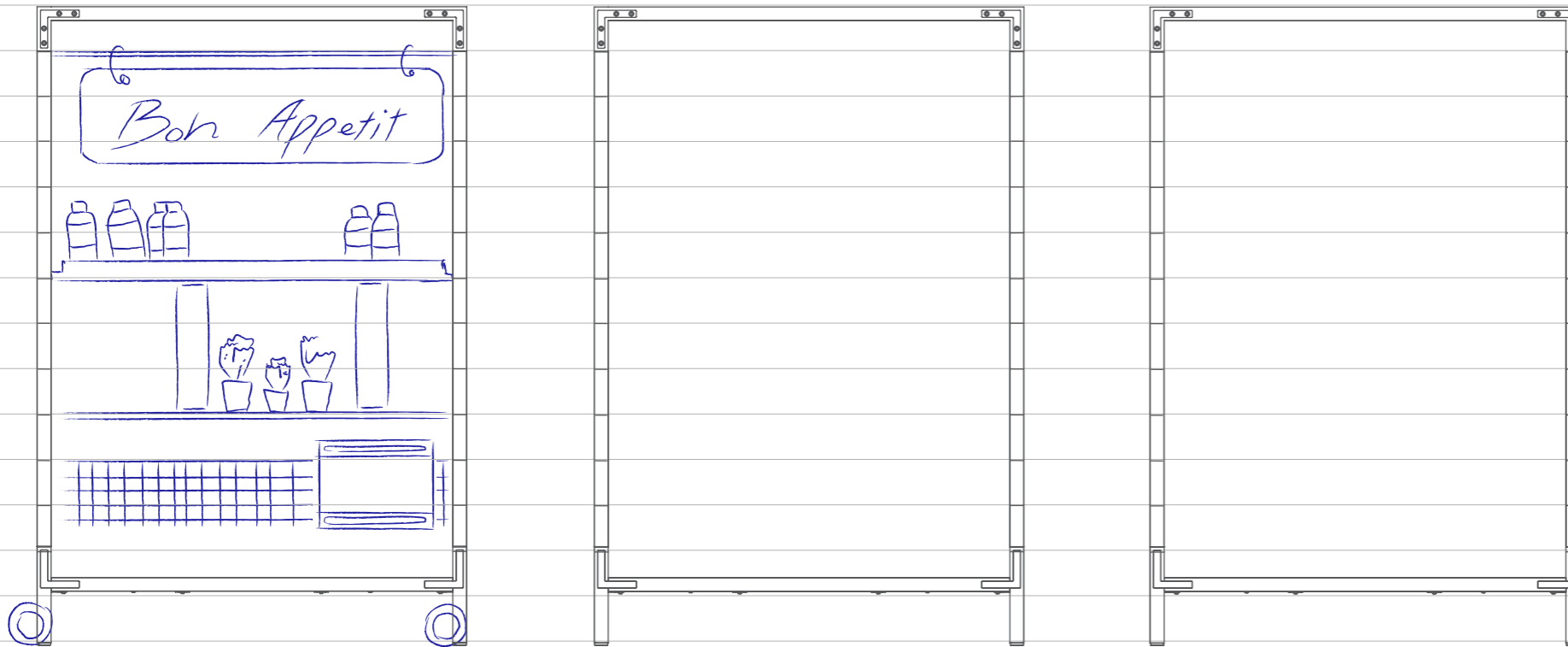

- TOP FRAME SHELF 
- SHELF 
- ANGLED SHELF 
- SHELF WITH BORDER 
- SHELF RETAINING BAR 
- SIGN 
- TOP FRAME HANGER BAR 
- HANGER BAR 
- CRATE 
- BOTTLE HOLDER 
- BUMPERS 
- ORGANIZER 

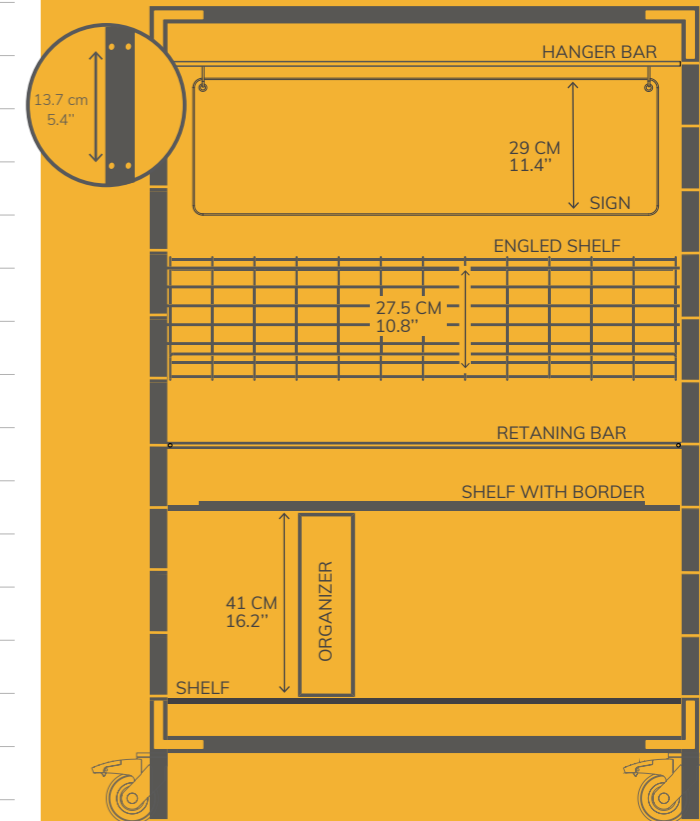
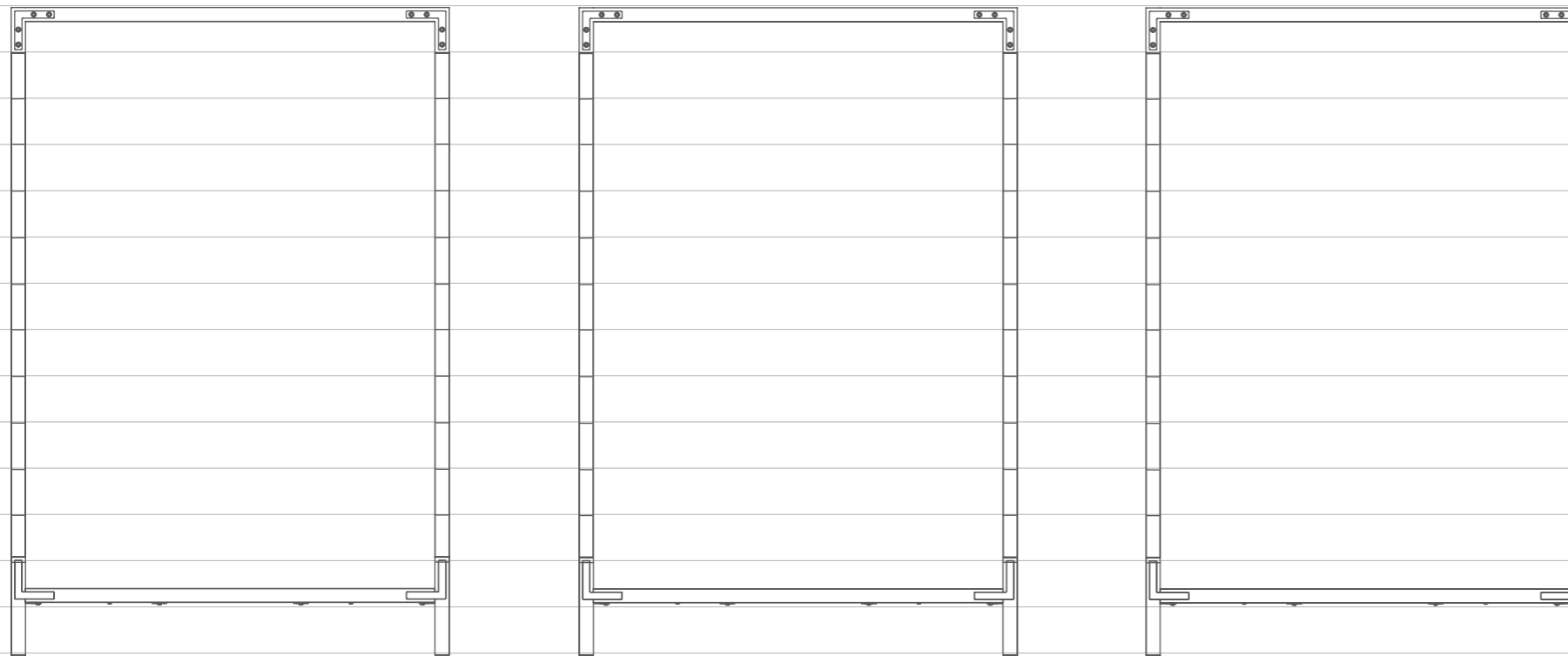



For more info  
about  
Canvas collection



US Patent no US010415618B2  
US Patent no US009210998B2  
More configurations can be found on our website.  
Dimensions are approximated due to conversions.  
The entire content is subject to misprints and errors.  
Item No. S-CTL-PR-10-01



[www.mogogo-buffet.com](http://www.mogogo-buffet.com)  
[info@mogogo-buffet.com](mailto:info@mogogo-buffet.com)

---

### CHECK OUT OUR OTHER COLLECTIONS



Modular  
SYSTEM



Roll'n  
SERVICE CARTS



Cantine  
DISPLAY CART



Grabit  
SIDE TABLES



Clix  
TABLES



Polo  
TABLES